

# POWERLINK



## ERC28, 36, 60 and 90 3 Phase Thyristor Controller instruction manual

### 1) Installation

The controller should be mounted to allow airflow through the heatsink naturally. The maximum ambient temperature should not exceed 40 Deg. C.

### 2) Protection Fuse

Suitable fuses should be fitted to protect an ERC connecting cables from overloading. The fuse level depends on the load current rating. The maximum fuse value for an ERC28 is 40A. The maximum fuse value for an ERC36 is 50A. The maximum fuse value for an ERC60 is 80A. The maximum fuse value for an ERC90 is 125A.

ERC28, 36, 60 & 90 have their own internal high speed semi-conductor fuses for protecting the switching devices. Their value are higher than the max. current rating due to the characteristics of these semi-conductor fuses. Please replace these fuses with the same ratings. A 100mA delay fuse which is on the print circuit board is used to protect the low voltage supply of the electronic control circuit.

### 3) Wiring

An ERC controller should be connected according to the wiring diagram as shown in fig. 1. The size of cables for controlling signals should be larger than 0.5 mm sq. and the cable to L, N and cables to the load must be sufficient to withstand the maximum current rating of the LOAD and meet the IEE WIRING REGULATIONS.

### 4) Set-up procedure

After connecting the load to a power controller, set the input signal to minimum (0V). Switch on the mains supply, the output voltage or current to the load should be zero (except the leakage current or snubber circuit current which is less than 10mA). Gradually increase the input signal and check that the output is switching ON and OFF according to the input signal.

### 5) ALL STANDARD UNITS ARE FACTORY SET UP AS FOLLOWS

- a) With the input at minimum (0V), switch on the mains supply to an ERC unit.
- b) With an input of 9V for 0-10V input range (for other input range, set the input to 90% of the max. input), adjust the SPAN pot clockwise until the output voltage or current is at maximum.
- c) With input signal at 8V, output should be nearly fully on with slightly off.
- d) With the input at 1V for 0-10V input range (for other input range, set the input to 10% of the max. input), adjust ZERO POT until the output is zero.
- e) With input signal at 2V, the output should be nearly fully off with slightly on.
- d) Repeat step b) and e) until the output is at maximum and zero.

### Specification

Supply voltage	380V to 415Vac, 47 to 63Hz
Input signal	0-10V as standard, 22 kilo-ohm min. input impedance
Current ratings per phase	Natural cooling ERC28 - 40A max. ; ERC36 - 50A max. ; ERC60 - 80A max. ; ERC90 - 125A max.
Cycle Time	adjustable from 2 to 35 sec.
Isolation	2500Vrms between input and output
Min. holding current	30mA
Operating temp.	0 to 45 Deg. C
Dimensions	ERC28 & 36 W: 155mm x H: 165mm x D: 110mm; DIN rail mounted ERC60 W: 280mm x H: 235mm x D: 150mm; panel mounted ERC90 W: 280mm x H: 315mm x D: 150mm; panel mounted
	Repetitive peak voltage 1200V Storage temp. -10 to 80 Deg. C

Powerlink Electronics Ltd, Powerlink House, Ivy Arch Road, Worthing, West Sussex, BN14 8BX.  
Tel: 01903209550 Fax: 01903213526

ERC28, 36, 60 & 90 WIRING DIAGRAM

INPUT SIGNAL	INPUT SWITCHES			
	SW1	SW2	SW3	SW4
0-5V	0	1	0	1
0-10V	0	1	0	0
0-20V	0	0	0	0
4-20mA	1	1	1	1

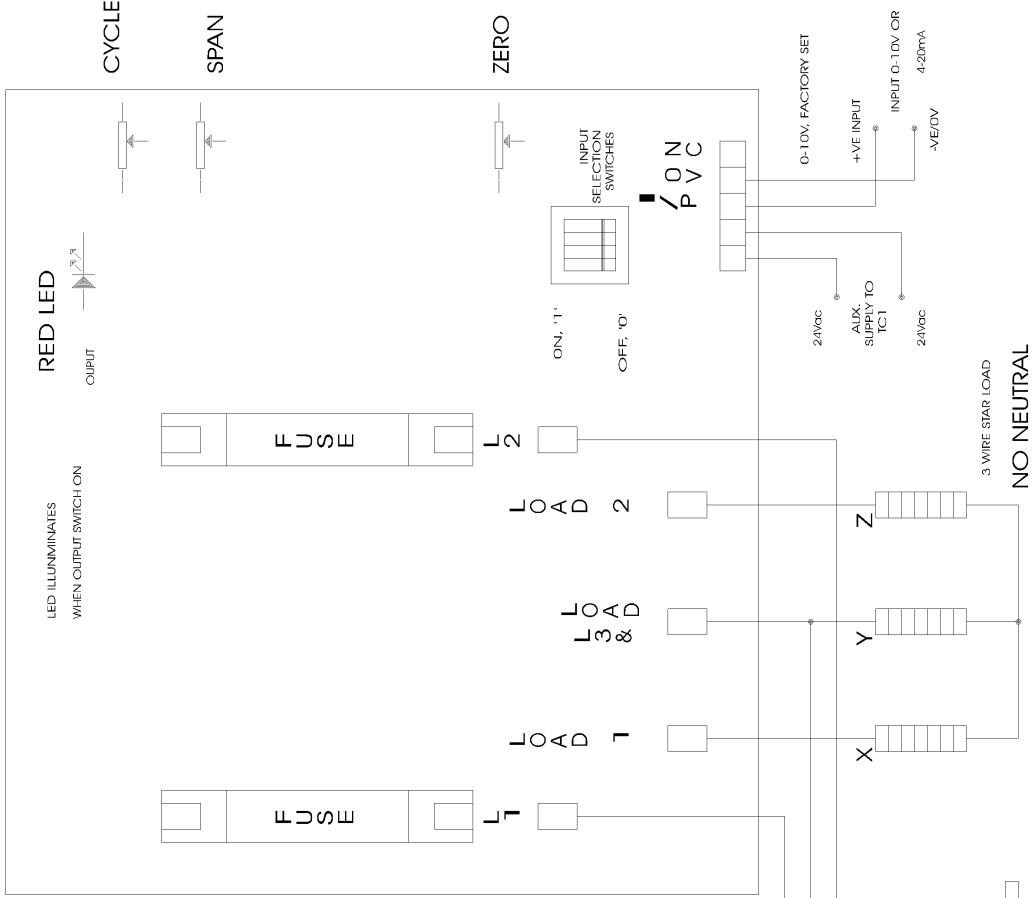

380V TO 415VAC

L1 L2 L3

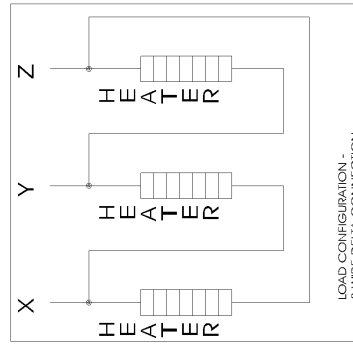

GC060707A